



**KIT PART NUMBER 4114094**

**INSTRUCTIONS FOR INSTALLING A REPLACEMENT PAN AND DRAIN IN AN ICE CREAM MERCHANDISER**

**CHECK THE PARTS RECEIVED IN THE KIT WITH THE PARTS LIST IN THESE INSTRUCTIONS. IF ANY PARTS ARE MISSING, CONTACT THE NATIONAL VENDORS PARTS DEPARTMENT IMMEDIATELY.**

**Read these instructions carefully before installing the kit.  
Keep these instructions for part numbers and for future reference.**

This kit contains the following:

INDEX	PART NUMBER	DESCRIPTION	QUANTITY
1	4114084	PLATE - EVAPORATOR - FAN & DRAIN	1
2	4042121	WIRE TIE - #PLT1M-M20	1
3	4114086	RETAINER - HEATER	1
4	4402043	NUT - #8032 W/L.W. - S.S.	4
5	4114089	TUBE - DRAIN - EXTENSION (17 1/4")	1
6	4114083	INSULATION - DRAIN	1
7	6234522	"T" UNION - BARBED	1
8	4114088	TUBE - DRAIN (15")	1
9	4305043	HARNESS CLIP - 1.00	1
-	4114095	INSTRUCTIONS - KIT	1

**ITEMS REQUIRED BUT NOT SUPPLIED**

RTV SEALANT
PERMAGUM
POP RIVETS (1/8" DIAMETER x 1/4" LONG) - ALUMINUM OR STAINLESS



Refer to the illustrations while performing the following steps:

See figure 1:

1. Turn the machine power switch OFF and unplug the machine from its power source.
2. Unlock and remove the upper rear access panel. Remove the lower rear access panel.

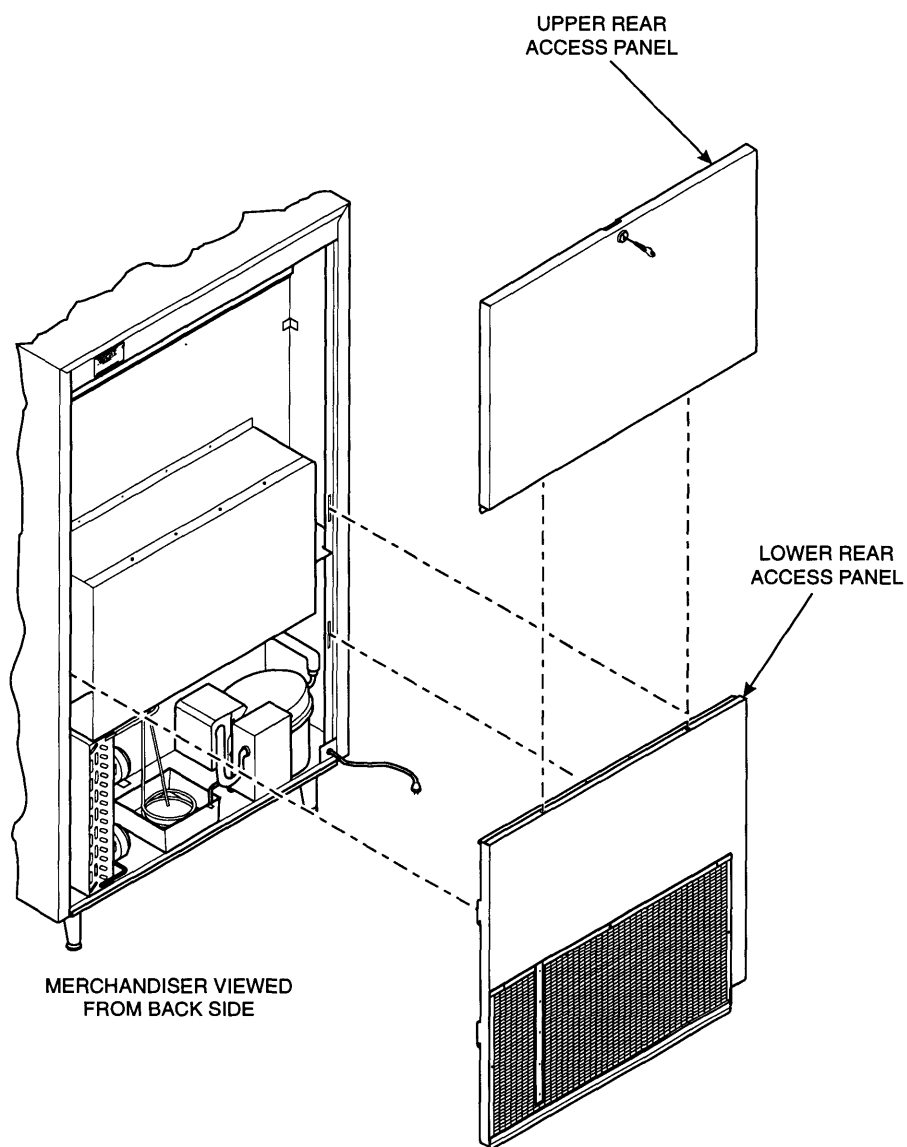

Figure 1



See figure 2:

3. Remove screws securing the evaporator coil cover. Remove the evaporator coil cover and coil back insulator.

**CAUTION**

***Be careful not to kink or damage the refrigeration tubing and other components.***

4. Carefully remove the evaporator and compressor assembly. Keep all screws and attaching hardware for later use.

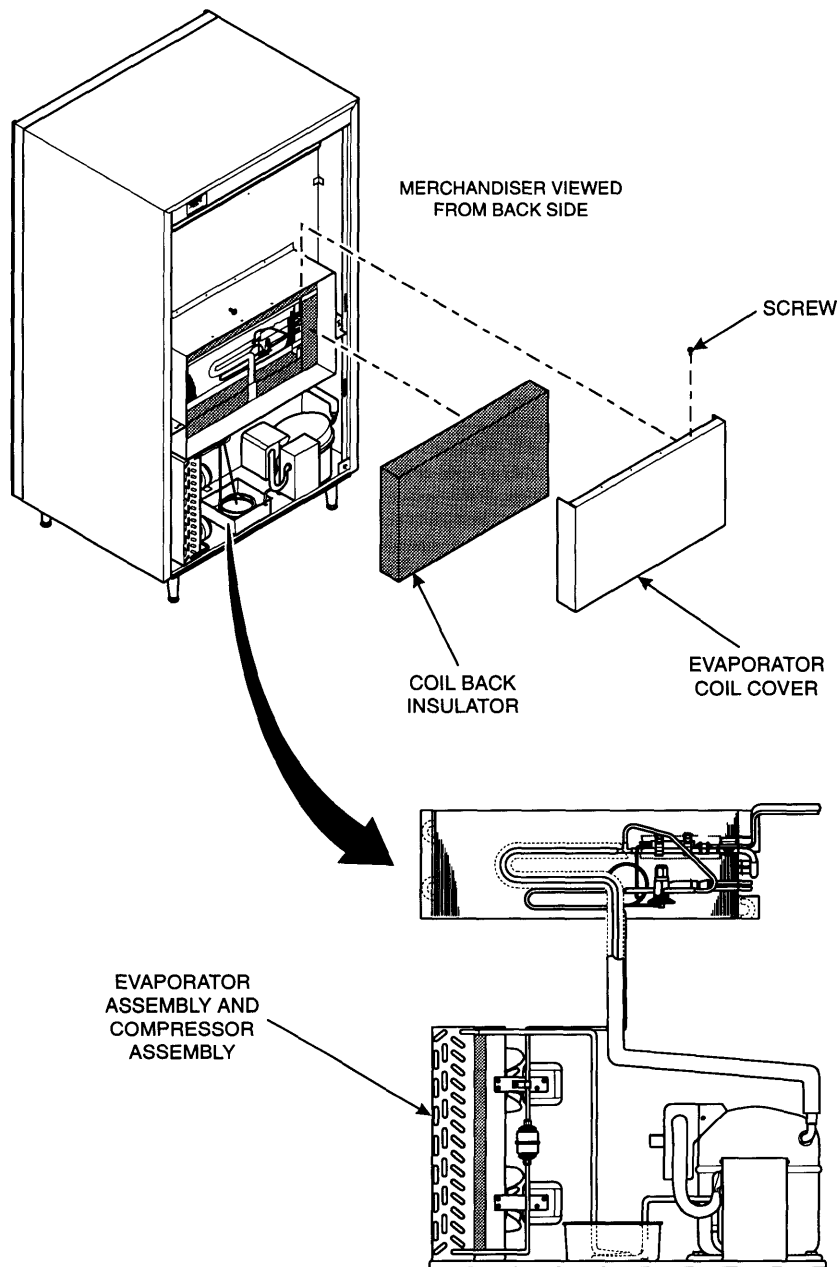

Figure 2



---

See figure 3:

5. Remove all wiring, clamps, and other items interfering with access to the evaporator fan and drain plate.
6. Using a Dremel® tool or equivalent, grind down all pop rivets until you can remove the evaporator fan and drain plate.
7. Remove the following parts from the evaporator fan and drain plate, but save them (and all hardware) for later use:
  - a. Fans and retaining clips
  - b. Heater - NOTE: Carefully peel the heater from the evaporator fan and drain plate
8. Discard the old evaporator fan and drain plate, and the old heater retainer.
9. Attach the old heater to the underside of the new evaporator fan and drain plate (1). Align the front edge of the heater flush with the front edge of the evaporator fan and drain plate, and the terminal end of the heater 1/4" away from the drain tube. (The heater should still be sticky enough to keep it attached to the evaporator fan and drain plate.) Secure the wire with the wire tie (2). Pull the wire tie tight.
10. Fit the new heater retainer (3) over the studs on the underside of the evaporator fan and drain plate. Secure with nuts (4); tighten snugly, but not too tight so as to avoid pinching the heater.
12. Install the old fans to the evaporator fan and drain plate.

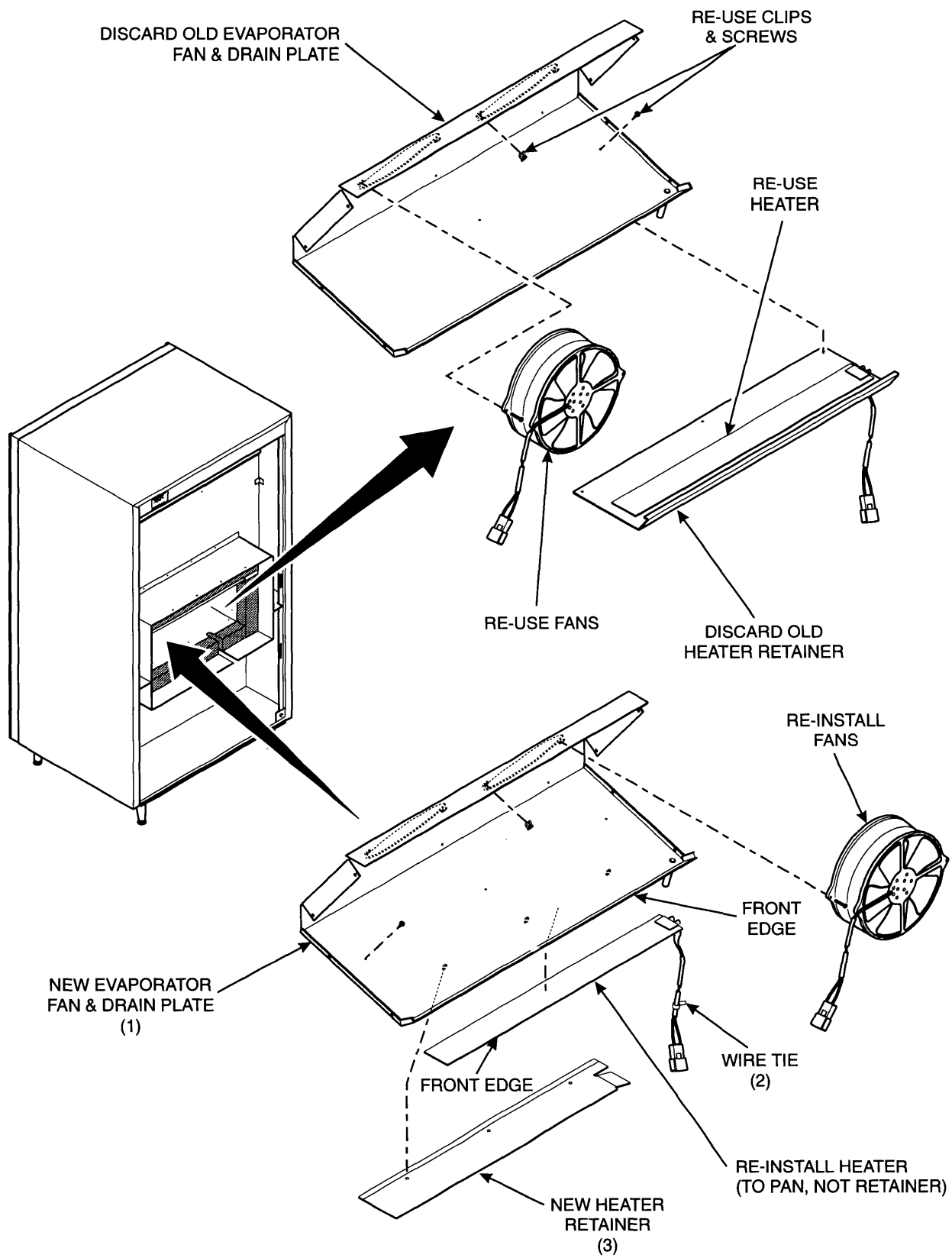

Figure 3



---

See figure 4:

13. Fit the drain extension tube (5) over the drain nipple in the bottom of the evaporator fan and drain plate.

**NOTE**

***Warming the tube or lubricating it with liquid soap will ease assembly.***

14. Insert the drain extension tube down through the hole in the merchandiser where the old drain tube was routed. Due to the increased diameter of the drain tube, the fit will be tight. You will have to feed the tube through this hole gradually while installing the evaporator fan and drain plate assembly. Route wiring to the right of the drain extension tube.
15. Secure the new evaporator fan and drain plate assembly to the inside of the merchandiser with pop rivets.
16. Apply RTV sealant to all joints.
17. Reinstall the evaporator assembly and compressor assembly. Secure it with its original hardware.
18. Fit the drain insulation (6) around the drain extension tube as shown. Secure it in place with RTV sealant.
19. Form a 2" trap in the drain extension tube. Install the "T" union (7) and drain tube (8) as shown. Route the drain tube into the pan in the lower part of the evaporator assembly as shown.
20. Connect the drain extension tube to the "T" union. Support it with the harness clip (9) as shown.
21. Apply permagum as shown, and to all other locations where it was in the original installation.
22. Reinstall the coil back insulator, the evaporator coil cover, and both access panels.
23. Apply power to the merchandiser and turn the power switch ON.

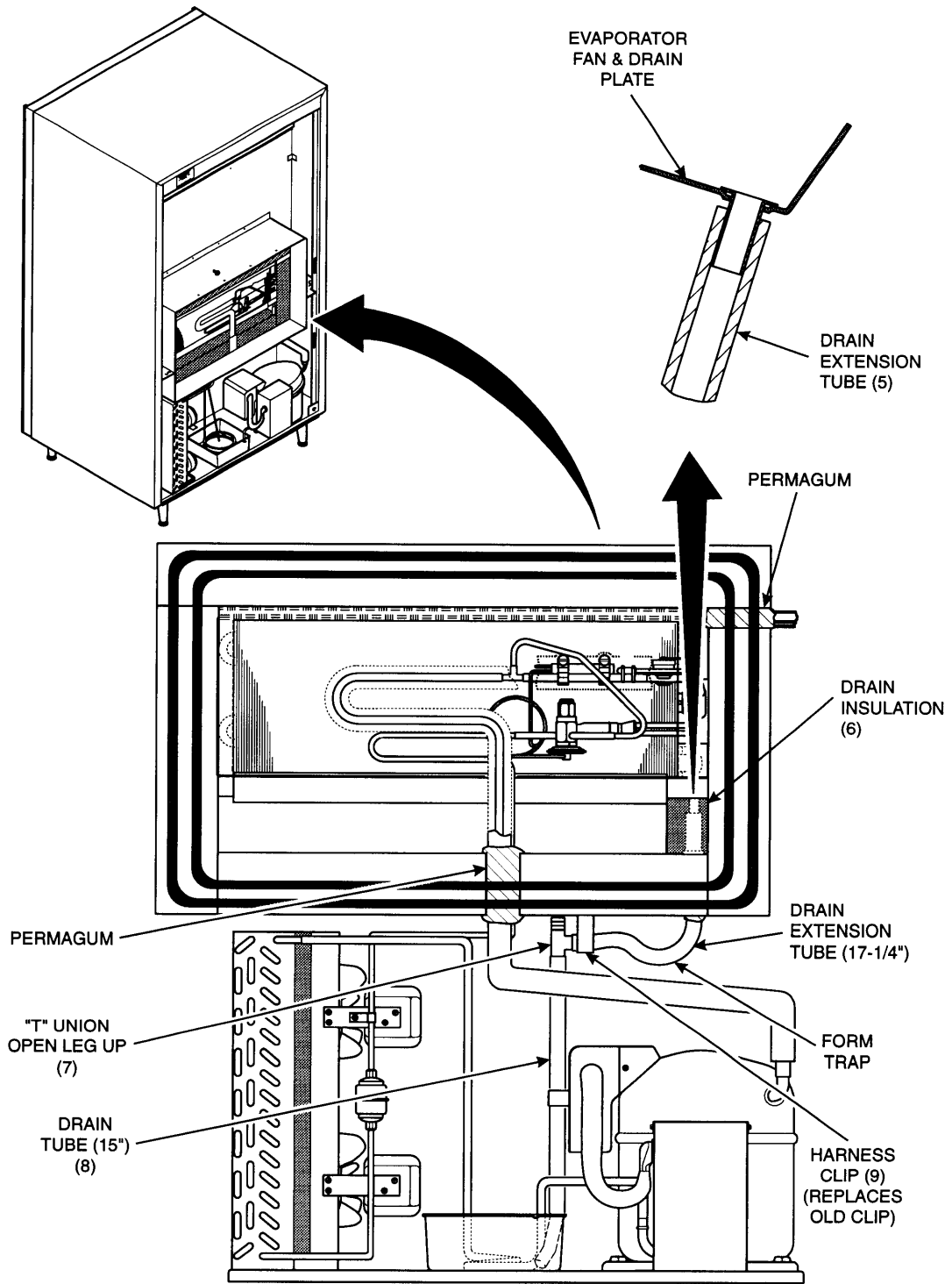

Figure 4